



Compliant



Smooth Gate Operation

# SAFEMEZZ360™

## THE ALL-ANGLES WAY TO PROTECT YOUR TEAM ON THE MEZZANINE

SafeMezz360™ is the latest fall-protection product for keeping personnel safe during the important, but potentially hazardous, job of loading and unloading forklifted materials to and from your mezzanine. The OSHA- and ANSI-compliant SafeMezz360 creates a foolproof enclosed area that keeps workers safe from the elevated mezzanine edge. It's available in single or double pallet widths.

### REDUCES ACCIDENTS

- Counter-balanced gate system provides 360 degrees of mezzanine ledge protection
- Slam-proof, cushioned dampening system keeps the gate from dropping on toes and protects personnel from dangerous and noisy slamming

### COMPLIES WITH OSHA AND ANSI STANDARDS

- Meets ANSI standards including the stringent ANSI MH28.3 Section 6.4.3 requirement
- Includes ANSI required 4-inch safety toeboard, preventing anything and anyone from falling off the mezzanine edge
- Meets OSHA Safety Railing Standards

### WITHSTANDS TOUGH WORK ENVIRONMENTS

- Constructed with heavy-gauge steel ideal for repetitive use
- Durable, safety yellow powder coat finish

### EASY TO INSTALL AND OPERATE

- Easy one-handed operation
- Gate opens and closes smoothly on 2" nylon rollers and track system

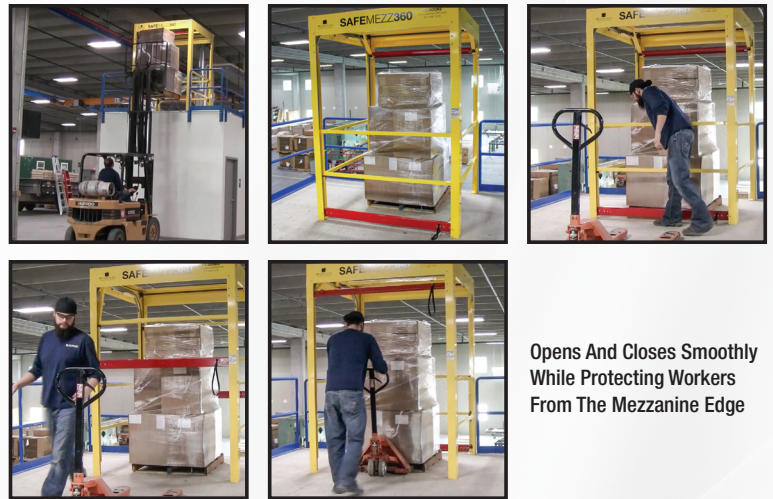

Opens And Closes Smoothly While Protecting Workers From The Mezzanine Edge

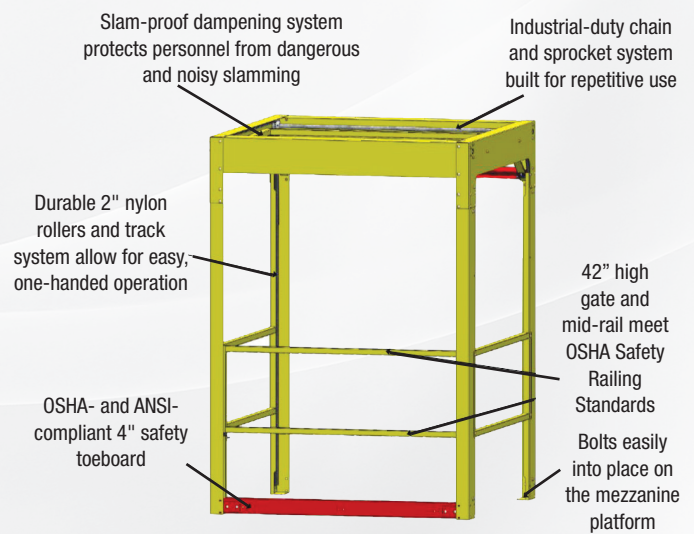

701.746.4519 | 877.446.1519 | [www.pssafetyaccess.com](http://www.pssafetyaccess.com) | [4psinfo@psindustries.com](mailto:4psinfo@psindustries.com)

## STANDARD TECHNICAL DATA

### MATERIAL:

- Top Assembly: Minimum of 12-gauge mild steel-formed shapes, factory-mounted galvanized radius/horizontal guide track assembly
- Column Assembly: 12-gauge mild steel-formed shape, factory-mounted galvanized vertical guide tracks
- Gate Assembly: 1-1/2" square, mild steel tube, minimum of 16-gauge wall; uninterrupted horizontal top rail, mid-rail, overall height of gate to be 42"; includes formed, 12-gauge mild steel, 4" high toeboard powder coat red for high visibility
- Hinge and Guide Roller Bracket: mild steel, black finish
- Guide Roller: 2" nylon, 11-ball bearing; provide six (6) per gate assembly
- Side Rail Assembly: 1-1/2" square, mild steel tube, minimum of 16-gauge, factory welded
- Gate Dampener System: Dual-dampening device, two (2) per unit
- Fasteners: Zinc plated

### FINISH:

- Finish on all exposed, non-prefinished components to be powder coat safety yellow

### HARDWARE:

- Operating Hardware: Heavy-duty chain, sprocket, shaft and bearings

### PERFORMANCE RATING:

- Gate shall meet or exceed OSHA/ANSI requirements at the time of manufacture relative to dimensions and loading
- One-year warranty from date of shipment, excluding finishes

### OPTIONS:

- Side toeboard – Additional toeboard protection at sides of SafeMezz360 assembly

### MEASURING GUIDE:

Product Number	Overall Height (A)	Clear Opening Height (B)	Clear Opening Width (C)	Overall Width (D)	Clear Depth (E)	Overall Depth (F)
SMZMM060	95"	80"	60"	68"	59.5"	66"
SMZMM100	95"	80"	100"	108"	59.5"	66"

**FRONT VIEW**

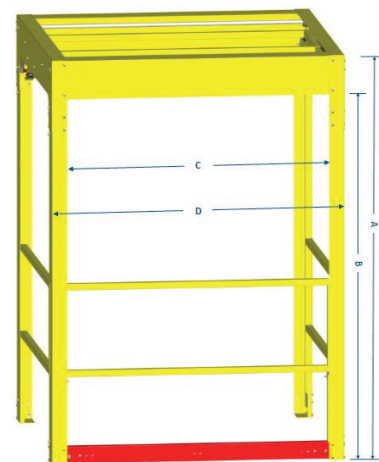

**SIDE PROFILE VIEW**

